

Molteni & C

D.859.1 TABLES — GIO PONTI 1959 / 2018

1—
2



In 1958 Gio Ponti was enlisted to design the auditorium for the Time&Life Building at 1271 Avenue of the Americas in New York. The building housed the headquarters of Time Inc., publisher of influential, historical magazines such as Time, Life, Fortune, People, and Sports Illustrated. This was Ponti's most prestigious project in New York. The D.859.1 table, designed primarily as a meeting table for up to ten people, stands out among the auditorium furnishings not only for its impressive size—over 3,60 meters long—but especially for its simple yet refined design. The legs are notable for their fine-membered modernity, creating a trapezoidal single-span bridge upon which the large tapered top conveys the idea of aerodynamics. Originally made of solid ash with brass ferrules, it is now also available in black stained ash. In addition to its original dimensions, the D.859.1 is available in two smaller version that faithfully reproduce the harmony and proportions of the original design.

DATASHEET

REGISTERED
DESIGN

IX.2021

FINISHES

STRUCTURE FINISH AND SOLID WOOD TOP
ash wood in natural colour
ash wood stained black

FEET
satin brass

NOTES
No reductions of any kind are possible.

TECHNICAL INFORMATION

STRUCTURE
In solid ash wood (Fraxinus excelsior) painted in the varieties according to product specifications.

FEET
Feet in satin finish brass and floor support in plastic material.

TOP
Composite support in Spruce slats (Picea abies) with external parts in high density fiber panel, covered with sliced veneer in Ash wood painted in the varieties according to product specifications.

Molteni & C

2—
2

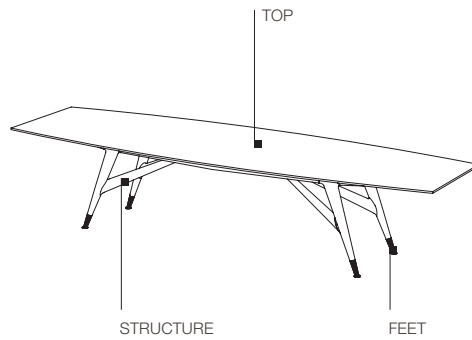

DIMENSIONS

table
D.859.1C

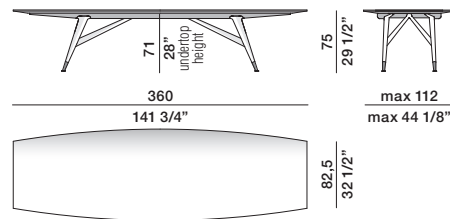

table
D.859.1B

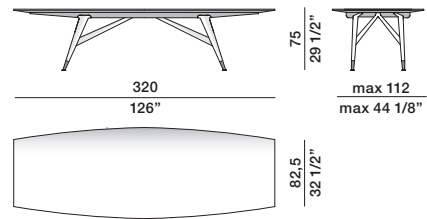
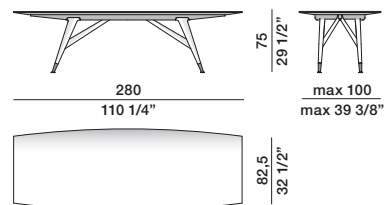

table
D.859.1A



DATASHEET

REGISTERED
DESIGN

IX.2021