

# Molteni & C

## RATIO

VINCENT VAN DUYSSEN, 2019

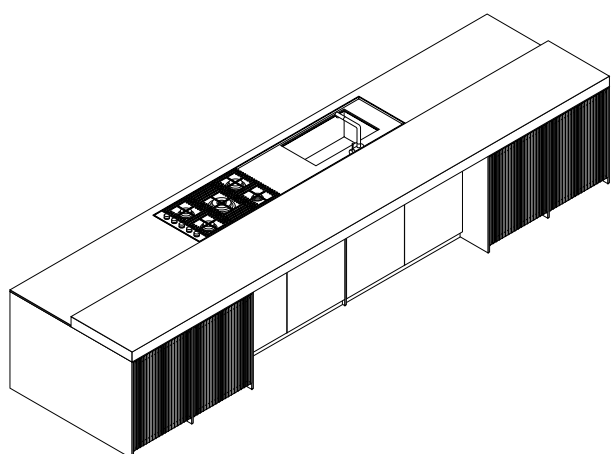

### FINITURE

#### Isola

Ante basi rovere nero con profilo maniglia peltro, base ante Stripe rovere nero con illuminazione interna, pannelli aggiuntivi e laterali laccato metallizzato peltro, top sp. 90mm pietra nero lava, top sp. 6mm acciaio inox, zoccolo peltro.

#### Colonne Atelier a giorno

Struttura rovere nero, con luce integrata nelle spalle, ripiani vetro extra chiaro, porta calici e bottiglie neri.

#### Colonne operative 2.0

Ante a scomparsa laccato Hybrid ardesia, maniglie Outline verticali peltro, basi interne Ratio rovere nero con profilo maniglia peltro, top sp. 90mm pietra nero lava, mensole Wing peltro con led, zoccolo peltro.



### PLUSES

- Design Vincent Van Duysen
- Cucina protagonista dello spazio
- Forte identità architeturale
- Giochi di superfici e spessori
- Rigore delle forme
- Design unico e riconoscibile
- Equilibrio di volumi pieni e vuoti

## Cucina con profilo maniglia



H. struttura base = 801 mm  
H. anta = 797 mm  
H. cucina con zoccolo da 60 mm = 861 mm  
H. cucina con zoccolo da 100 mm = 901 mm  
SP. pannello anta 13 mm  
(alluminio + MDF stratificato)  
SP. profilo maniglia 28 mm  
SP. anta doghe 30 mm  
D. Base = 331-595-745mm

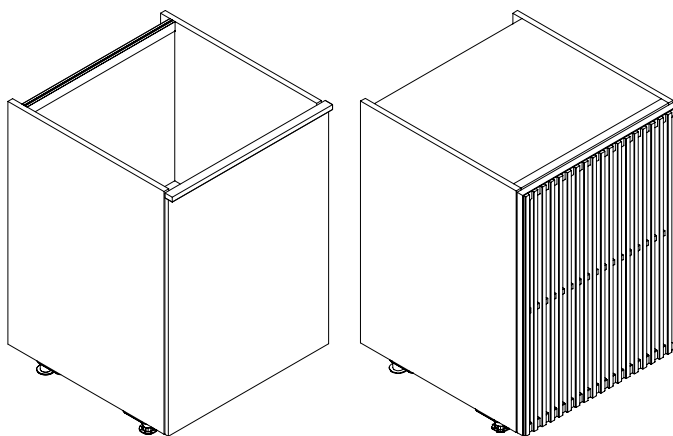

## Anta con profilo maniglia

L'anta ultrasottile brevettata da 13 mm è l'elemento chiave della composizione. Ratio fonde perfettamente elementi orizzontali e verticali, che racchiudono e delineano le ante, donando un aspetto distinto. Questo design è offerto anche dal profilo maniglia, caratterizzato da una finitura in bronzo o zinco.

**A**  
Primo frontale in alto

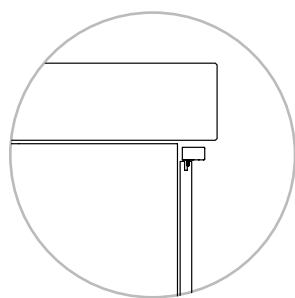

**B**  
Opzione con profilo maniglia

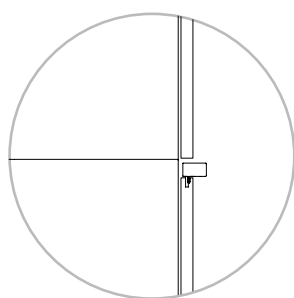

**C**  
Opzione con premi-apri manuale  
o elettrico

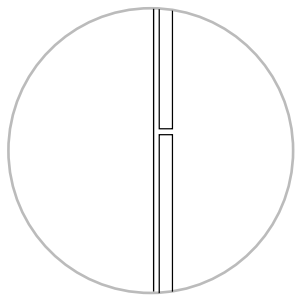

2-  
8

# Molteni & C

## Top

Anta sp 13 mm

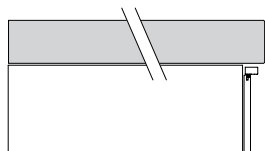

Composizione a parete

struttura	top
331	364
595	628
745	778

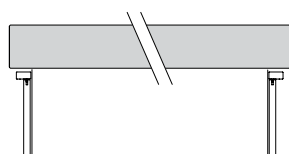

Isola

struttura	top
595	661
331 + 595	992
595 + 595	1156
745	811
745 + 331	1142

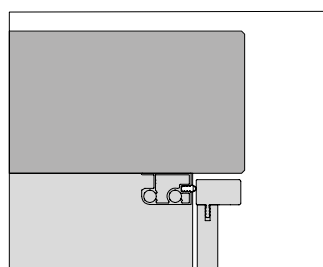

 sp. 90 mm



### FINITURE

Pietre  
Silestone  
Dekton  
Materia  
Ceramica



3-  
8

# Molteni & C

## Isola

Vincent Van Duysen propone una soluzione ad isola con mobili ed accessori con lo scopo di soddisfare l'utilizzatore più esigente e sofisticato. Non mancano poi piani snack, soluzioni per le zone lavaggio e cottura innovative e perfettamente integrate nel progetto.

1. Struttura portante con spalle ponte
2. Basi centrali H 631 mm
3. Basi terminali H 431 mm
4. Base lavello terminale H 431 mm
5. Pannelli terminali aggiuntivi
6. Tavolo snack sp 62 mm
7. Top sp 90 mm a sbalzo su snack
8. Lavello terminale Ratio

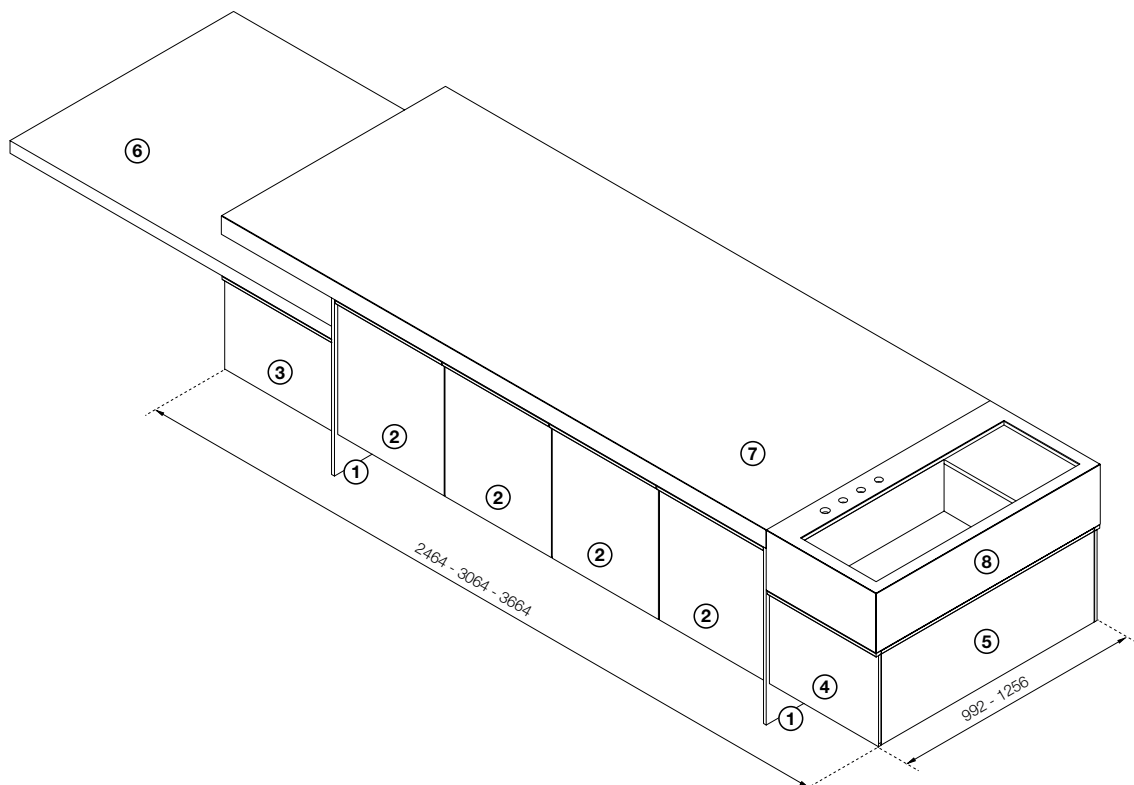

# Molteni & C

## Lavello Ratio

Il lavello Ratio è stato progettato per l'omonima cucina. Viene posizionato in testa all'isola. Viene collocato solo su basi terminali dedicate.

- disponibile in due dimensioni: L 992 / L 1256
- finiture silestone, materia, Dekton, ceramica, marmo/granito/pietra
- possibilità di scegliere posizione sgoccolatoio, destra o sinistra

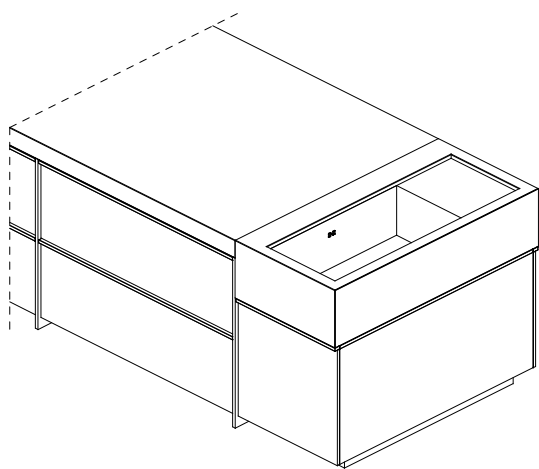

## Tavolo snack Dine

- Tavolo snack sp. 62 mm
- Disponibile nelle essenze di gamma
- Il piano snack può essere posizionato perpendicolarmente all'isola o allineato al top



FINITURA TOP  
Essenza

FINITURA STRUTTURA  
Essenza

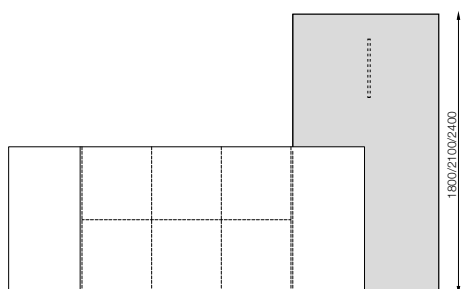
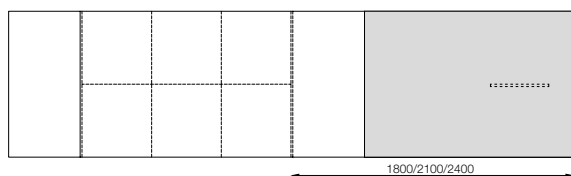
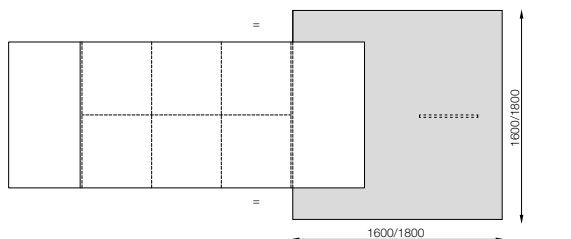

6  
8

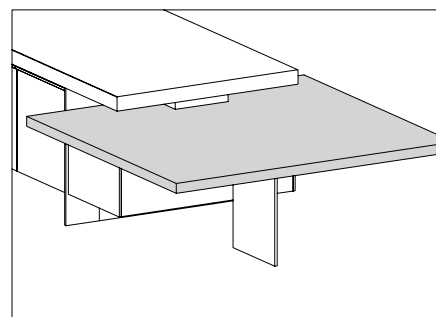
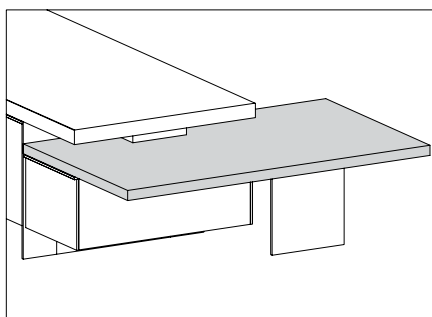
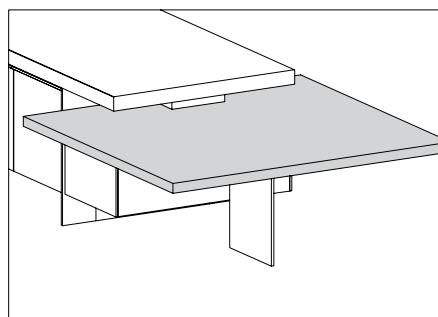

## Composizione



### FINITURE

#### ISOLA RATIO

Ante basi rovere nero  
 Profilo maniglia peltro  
 Base anta Stripe rovere nero  
 con illuminazione interna  
 Pannelli aggiuntivi e laterali  
 laccato metallizzato peltro  
 Top sp. 90mm pietra nero lava  
 Zoccolo peltro

#### COLONNE ATELIER A GIORNO

Struttura rovere nero  
 Luce integrata nelle spalle  
 Ripiani vetro extra chiaro  
 Porta calici e bottiglie neri

#### COLONNE OPERATIVE 2.0

Ante a scomparsa laccato  
 Hybrid ardesia  
 Maniglie Outline verticali peltro  
 Basi interne Ratio rovere nero  
 con profilo maniglia peltro  
 Top sp. 90mm pietra nero lava  
 Mensole Wing peltro con led  
 Zoccolo peltro

VISTA IN PIANTA

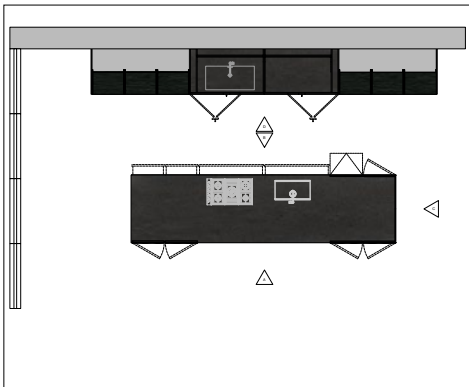

VISTA FRONTALE

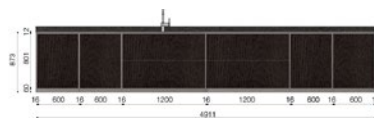
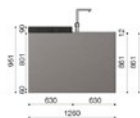
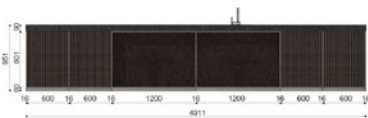
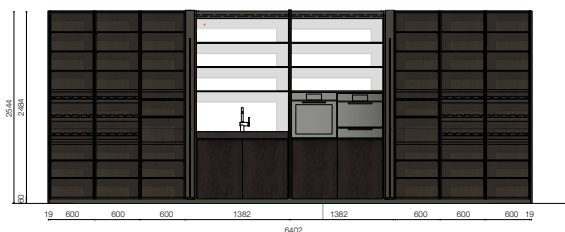

# Molteni & C

## Doors finishes

### LO, LL

#### LACQUERED | LACCATI

<b>WHITE</b> BIANCO	<b>CHALK WHITE</b> BIANCO CALCE	<b>PEARL</b> PERLA
<b>SILICA</b> SILICE	<b>SAND</b> SABBIA	<b>DUNE</b> DUNA
<b>LIGHT GREY</b> GRIGIO CHIARO	<b>DOVE GREY</b> TORTORA	<b>PLATINUM</b> PLATINO
<b>CLAY</b> ARGILLA	<b>DOLOMITE</b>	<b>LEAD</b> PIOMBO
<b>MOKA</b>	<b>LIGHT BLUE GREY</b> CARTA DA ZUCCHERO	<b>MUSTARD</b> SENAPE
<b>ANTHRACITE</b> ANTRACITE	<b>BLACK</b> NERO	<b>COPPER</b> RAME
<b>LONDON SKY</b>	<b>STARDUST</b>	<b>MOONLIGHT</b>
<b>SPICE</b>	<b>PINE GREEN</b>	<b>ALMOND WHITE</b>

### LOS

#### SPECIAL METALLIZED LACQUERED | LACCATI SPECIALI METALLIZZATI

<b>GOLD</b> ORO	<b>IRIS</b>	<b>PEWTER</b> PELTRO
<b>BRONZE</b> BRONZO		

### LSH

#### HYBRID LACQUERED | LACCATI HYBRID

<b>METAL HYBRID BRONZE</b> METALLIZZATO BRONZO HYBRID	<b>METAL HYBRID SLATE</b> METALLIZZATO ARDESIA HYBRID
---	---

### ES

#### WOODS | ESSENZE

<b>SUNRISE OAK</b> ROVERE SUNRISE	<b>WALNUT</b> NOCE	<b>EUCALYPTUS</b> EUCALIPTO
<b>GRAPHITE OAK</b> ROVERE GRAFITE	<b>DARK WALNUT</b> NOCE SCURO	<b>BLACK OAK</b> ROVERE NERO
<b>THERMO OAK</b> ROVERE TERMO	<b>DARK PALM</b> PALMA SCURO	<b>LIGHT ELM</b> OLMO CHIARO
<b>DARK ELM</b> OLMO SCURO		

### ESR

#### RAYS

<b>SUNRISE OAK</b> ROVERE SUNRISE	<b>WALNUT</b> NOCE	<b>EUCALYPTUS</b> EUCALIPTO
<b>GRAPHITE OAK</b> ROVERE GRAFITE	<b>THERMO OAK</b> ROVERE THERMO	<b>DARK WALNUT</b> NOCE SCURO
<b>BLACK OAK</b> ROVERE NERO		