

Molteni & C

ARMAND — CHRISTOPHE DELCOURT 2026

1—
2



The Armand armchair is a compelling combination of leather craftsmanship, fine woodworking, and sculpted polyurethane padding. The enveloping leather backrest extends to form the arms, supporting the solid wood legs. Elegant and well-proportioned, the legs introduce an expressive structural detail to this sculptural armchair design. With Armand, Christophe Delcourt signs an armchair for Molteni&C that reveals absolute technical mastery and an exceptional level of sophistication, with every constructive detail contributing to a coherent and timeless vision.



This symbol shows that the product has removable upholstery. Only qualified personnel can remove the upholstery of some of our products. If this information is pertinent, it will be included in the warnings section.



This symbol shows that the product is available on request in a fire resistant version that complies with the standards BS 5852 and TB 117-2013. The buyer is responsible for checking to make sure that the product is suitable and compliant with the requirements for the designated use and the current applicable laws and standards for the destination and use of the product.

DATASHEET

REGISTERED
DESIGN

2026

moltenigroup.com

Dimensions in centimeters and inches. The right to discontinue and make changes is reserved. This information is based on the latest product information available at the time of printing.

FINISHES

FEET FINISHES
solid wood stained:
coffee oak
amber oak

BONDED HIDE LEATHER FINISHES
ivory
dark brown
natural
mud green
dove grey
black
colonial
hazelnut

Molteni & C

TECHNICAL INFORMATION

PERIMETER STRUCTURE

Steel sheet covered in bonded hide leather, with feet in stained solid ash and ferrules in non-slip plastic.

SEAT STRUCTURE

Plywood frame with elastic straps and cover in bonded cotton-polyester fibre velveteen.

SEAT CUSHION

Variable-density shaped polyurethane with cover in velveteen bonded with polyester fibre/cotton.

BACKREST STRUCTURE

Thermoformed plastic covered in bonded hide leather.

BACK CUSHION

Internal structure in polimex (composite polyester/polyurethane material) covered with variable-density, high-resistance polyurethane foam with cover in velveteen bonded with polyester fibre/cotton.

REMOVABLE OUTER COVER

(See attached card, specifically for the cover).



AVAILABLE IN FIRE-RESISTANT
VERSION TB117 AND BS5852

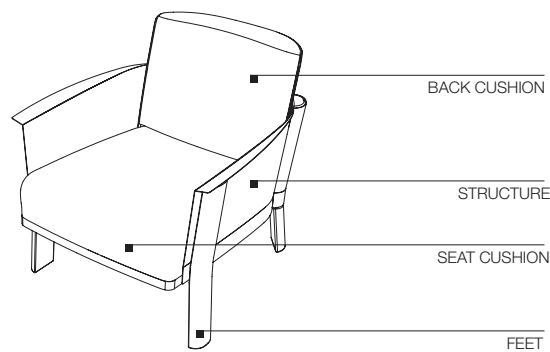

DIMENSIONS

armchair

APL1

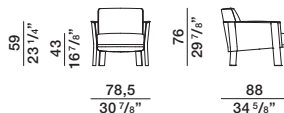

DATASHEET

REGISTERED
DESIGN

2026

