

# Molteni & C

## **BELSIZE** — RODOLFO DORDONI 2017

1—  
3



Designed for various functions; small coffee or occasional tables, they can be included in the components of the Sloane system to create articulated compositions. In the version with tall legs they become desks or small breakfast or cocktail tables.

### **FEATURES**

Set of table tops in various shapes and materials, standing on thin legs, always with a pewter colour finish.

#### **DATASHEET**

REGISTERED  
DESIGN

IX.2018

## FINISHES

### FINISHES OF TABLES TOPS WITH PEWTER COLOUR LEGS

eucalyptus  
graphite oak  
glossy clay  
glossy anthracite  
glossy rust

### FINISHES OF MARBLE TOPS ON BTV1 - BTV5 - BTV6

orient grey  
black marquina

# Molteni & C

2—  
3

## TECHNICAL INFORMATION

### LEG

Tapered, painted metal tube. Bracket for fastening to the painted die-cast aluminium top.  
Painted metal ferrule with non-slip rubber pad.

### WOOD TOP

Medium density fibre panel covered with Eucalyptus wood veneer (*Eucalyptus globulus*) and Oak (*Quercus*) or finished in glossy lacquer in range colours.

### MARBLE TOP

Marble in range finishes.

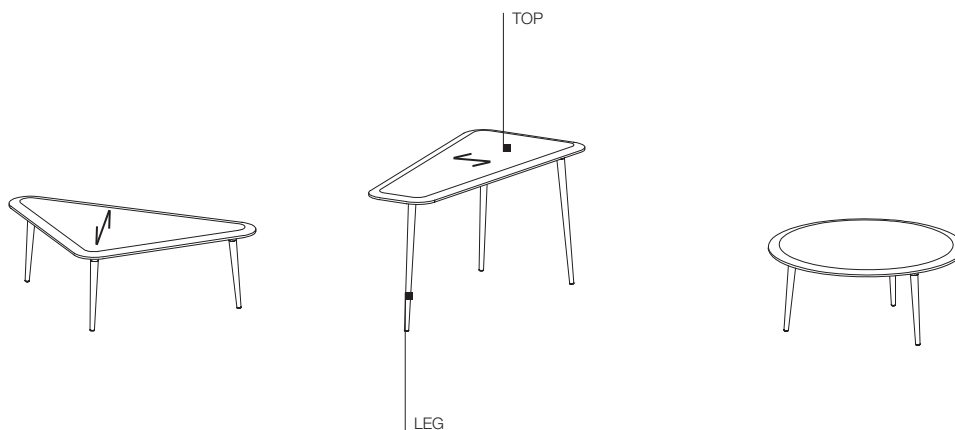

## DATASHEET

REGISTERED  
DESIGN

IX.2018

**DIMENSIONS**

**small tables**

**BTV1**

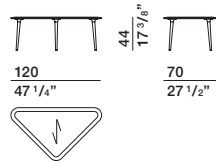

**BTV2**

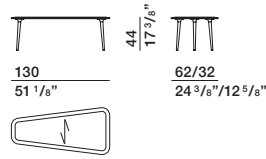

**BTV5**

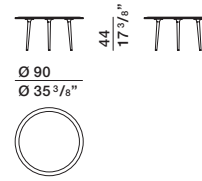

**BTV4**

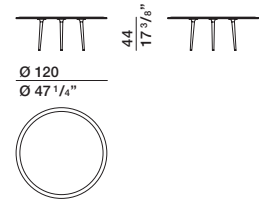

**Molteni & C**

**consoles**

**BTV3**

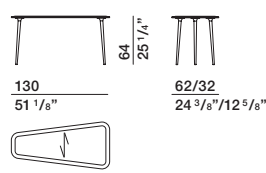

**BTV6**

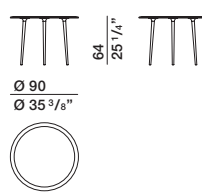

**BTV7**

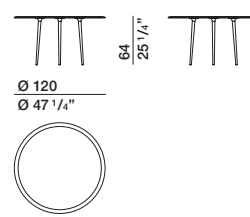

**Molteni & C**

**FINISHES  
MOLTENI&C  
RANGE**  
IX.2018

	MATT LACQUER	GLOSSY LACQUER	COLOURED GLASS	ETCHED COLOURED GLASS	CARTAPAGLIA LACQUERED only Gliss Master	STOPSOL GLASS TRANSPARENT STOPSOL GLASS
CHALK WHITE	•	•	•	•	•	
PEARL	•	•	•	•	•	
SILICA	•	•	•	•	•	
SAND	•	•	•	•	•	
DOVE GREY	•	•	•	•	•	
PLATINUM	•	•	•	•	•	
DUNE	•	•	•	•	•	
CLAY	•	•	•	•	•	
DOLOMITE GREY	•	•	•	•	•	
COPPER	•	•	•	•	•	
RUST	•	•	•	•	•	
RUBY	•	•	•	•	•	
CARAMEL	•	•	•	•	•	
MOKA	•	•	•	•	•	
MUSTARD	•	•	•	•	•	
LIGHT BLUE GREY	•	•	•	•	•	
PEWTER COLOUR	•	•	•	•	•	
ANTHRACITE	•	•	•	•	•	
BLACK	•	•	•	•	•	
STOPSOL						•
LESSLESS RED	•					
	only matt lacquer					

The finishes shown are indicative and refer to the entire production range. We recommend that you consult the "Colour Range" samples which show the complete range of finishes, including those not shown here. Molteni&C reserves the right to modify the range without warning.

#### WOODS

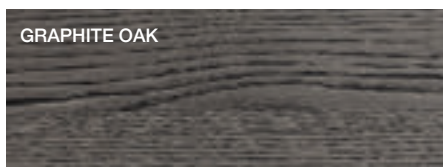
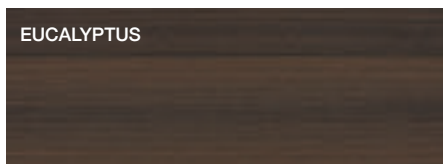

#### MARBLES

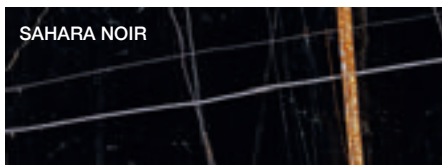
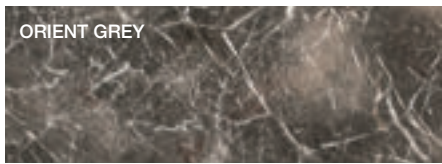
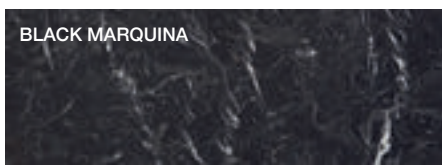
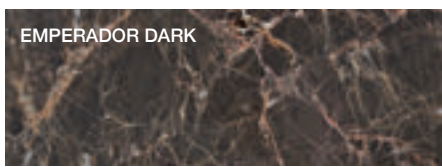
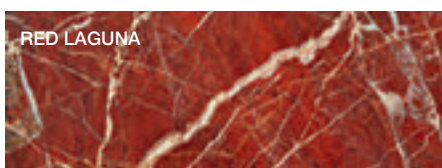
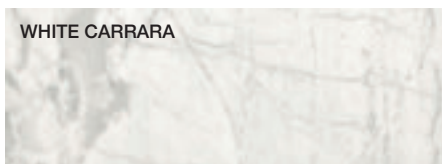

#### METAL PARTS

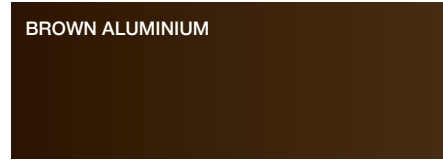
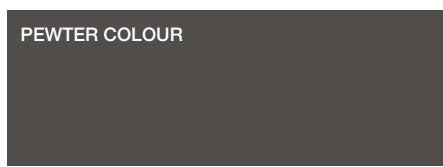
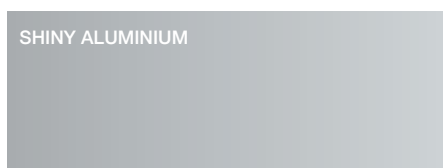
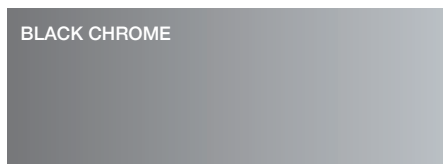

**MELAMINE FRONT**  
GLISS MASTER

CARTAPAGLIA WHITE

CARTAPAGLIA ANTHRACITE

CARTAPAGLIA SILICA

GRAFFIATO SILICA

GRAFFIATO BRONZE

SILK DOVE GREY

SILK SILICA

SILK CHALK WHITE

**MELAMINE STRUCTURE**  
GLISS MASTER

WHITE SHANTUNG

GREY SHANTUNG

**MELAMINE STRUCTURE**  
GLISS MASTER, MASTER DRESSING,  
GLISS WALK-IN

SILVER CEMBRAN

LARIX DARK

**MELAMINE STRUCTURE**  
GLISS MASTER, MASTER DRESSING

WHITE

**ECO SKIN**

IVORY

HEMP

MINK

DARK BROWN

GREY

**FINE GRAIN**

FINE GRAIN