

Molteni & C

INK — JASPER MORRISON 2016

1—
2



“The formal appearance of an object should not just be the result of hours spent analyzing the problem or producing a large number of drawings. In many cases it is the visual consequence of an idea, of a process, of a function or simply of an intuition” writes Jasper Morrison in *A Book of Things*, Lars Mueller Publisher, 2015. With these convictions, Jasper Morrison designed Ink, a desk where the form is a consequence of the purpose. A desk is more of a place than an object. That is where ideas take shape and are turned into writings or projects. Concentration is the main requisite. Ink is made of American walnut, it is trapezoidal in shape and you access it by opening a door which is tilted to become a work top. Inside the compartment, three drawers, LED lighting and another compartment fitted with sockets for connecting all kinds of electronic devices, even if the name Ink recalls traditional handwriting done with pen, ink and paper, but above all with ideas.

FEATURES

The inner compartment includes three drawers and an electrified insert. The writing desk is available in two versions: with or without inner lighting.

DATASHEET

REGISTERED
DESIGN

IX.2018

FINISHES

American walnut

TECHNICAL INFORMATION

COVER, LOWER SHELF DRAWER BLOCK, BACK, SIDES AND DOOR

MDF composite panel and aluminium sheet th. 0.8mm, covered in veneer from American walnut (Juglans Nigra). Door and sides contain internal metal parts for the opening mechanism.

BASE

MDF composite panel and aluminium sheet th. 0.8mm, covered in veneer from American walnut. Front part in solid American walnut wood.

DRAWER BLOCK AND DRAWER INTERIORS

Medium density fibreboard panel with American walnut veneer.

DRAWER FRONTS

In solid American walnut wood with American walnut veneer.

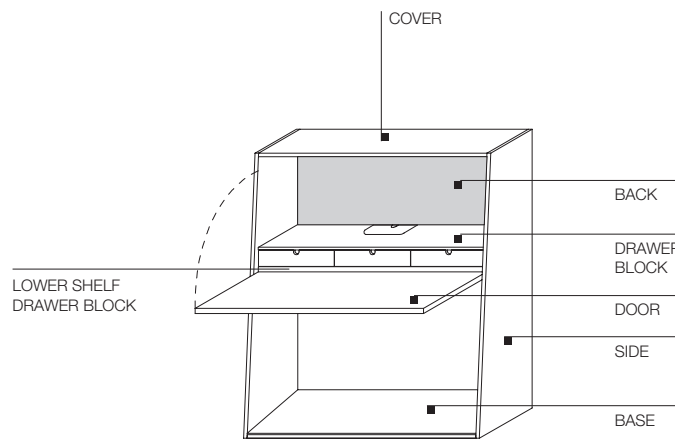

DIMENSIONS

writing desk without inner lighting

ISC11/13

flap closed

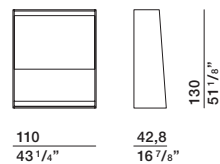

flap open

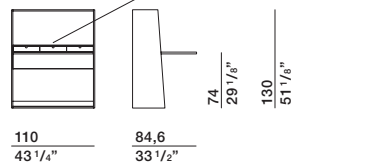

writing desk with inner lighting

ISC11/13K

flap closed

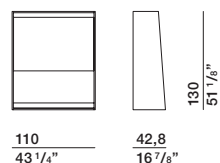

flap open

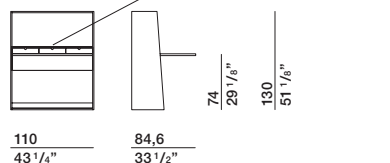

DATASHEET

REGISTERED
DESIGN

IX.2018

Molteni & C

**FINISHES
MOLTENI&C
RANGE**
IX.2018

	MATT LACQUER	GLOSSY LACQUER	COLOURED GLASS	ETCHED COLOURED GLASS	CARTAPAGLIA LACQUERED only Gliss Master	STOPSOL GLASS TRANSPARENT STOPSOL GLASS
CHALK WHITE	•	•	•	•	•	
PEARL	•	•	•	•	•	
SILICA	•	•	•	•	•	
SAND	•	•	•	•	•	
DOVE GREY	•	•	•	•	•	
PLATINUM	•	•	•	•	•	
DUNE	•	•	•	•	•	
CLAY	•	•	•	•	•	
DOLOMITE GREY	•	•	•	•	•	
COPPER	•	•	•	•	•	
RUST	•	•	•	•	•	
RUBY	•	•	•	•	•	
CARAMEL	•	•	•	•	•	
MOKA	•	•	•	•	•	
MUSTARD	•	•	•	•	•	
LIGHT BLUE GREY	•	•	•	•	•	
PEWTER COLOUR	•	•	•	•	•	
ANTHRACITE	•	•	•	•	•	
BLACK	•	•	•	•	•	
STOPSOL						•
LESSLESS RED	•					
	only matt lacquer					

The finishes shown are indicative and refer to the entire production range. We recommend that you consult the "Colour Range" samples which show the complete range of finishes, including those not shown here. Molteni&C reserves the right to modify the range without warning.

WOODS

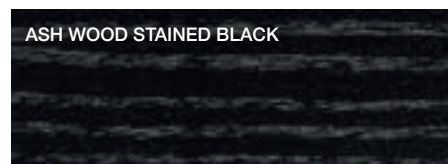
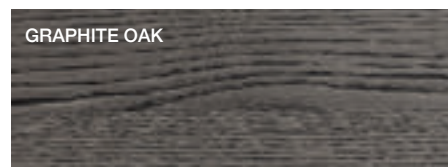
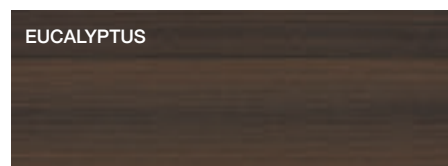

MARBLES

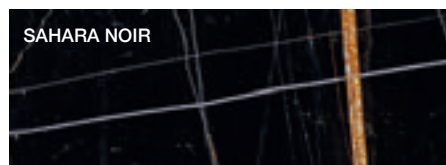
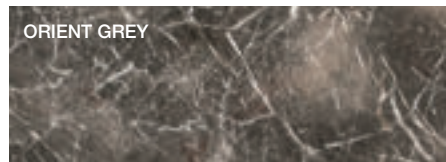
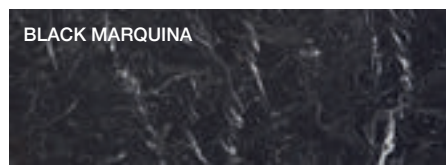
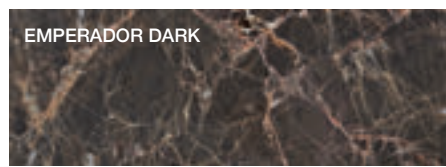
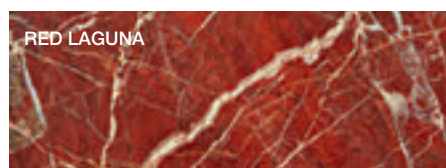
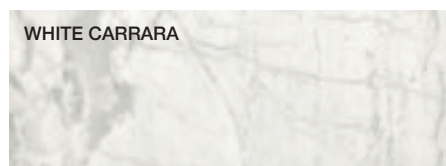

METAL PARTS

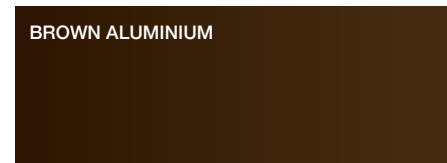
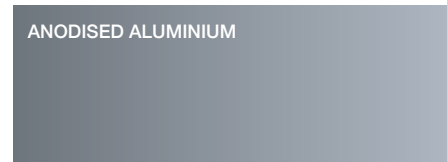
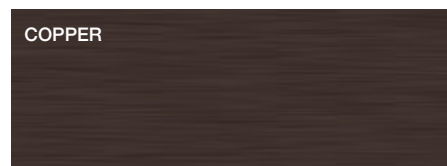
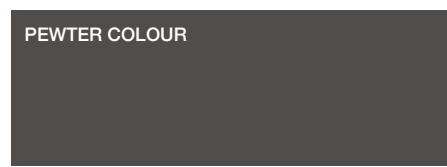
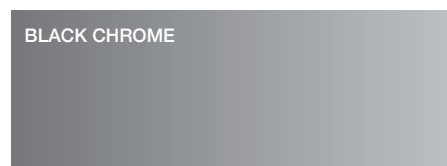

MELAMINE FRONT
GLISS MASTER

CARTAPAGLIA WHITE

CARTAPAGLIA ANTHRACITE

CARTAPAGLIA SILICA

GRAFFIATO SILICA

GRAFFIATO BRONZE

SILK DOVE GREY

SILK SILICA

SILK CHALK WHITE

MELAMINE STRUCTURE
GLISS MASTER

WHITE SHANTUNG

GREY SHANTUNG

MELAMINE STRUCTURE
GLISS MASTER, MASTER DRESSING,
GLISS WALK-IN

SILVER CEMBRAN

LARIX DARK

MELAMINE STRUCTURE
GLISS MASTER, MASTER DRESSING

WHITE

ECO SKIN

IVORY

HEMP

MINK

DARK BROWN

GREY

FINE GRAIN

FINE GRAIN